



IP67
至高防护等级
Highest protection grade

25kW
大起升功率
High lifting power

三电水冷
Motor, electric control,
battery water cooling
30度电池及以上
30 kWh battery and above

7寸大屏
7-inch large screen
标配智能仪表
Standard intelligent instrument

自研云平台
Self-developed cloud platform
智能监控护航
Intelligent monitoring
and protection escort

标配T-BOX
Standard T-BOX
远程升级和锁车
Remote upgrade and locking

剑奇版(Jianqi Edition) **SCP30F1/ SCP35F1**

三一锂电平衡重叉车

SANY Lithium Battery-powered Counterbalanced Forklift

三一机器人科技有限公司
SANY Robotics Technology Co., Ltd.

卓越性能

Outstanding Performance

新能源汽车技术与叉车完美融合，全面替代油车。

Perfect integration of new energy vehicle technology with forklifts, fully replacing traditional diesel options.



汽车级VCU

自研超强算力双核心VCU，毫秒级响应，驾控爆发力强

Automotive-grade VCU

Self-developed dual-core VCU offers powerful computing capabilities with millisecond response time for superior control

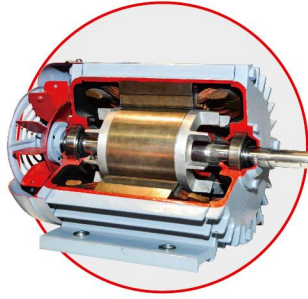

汽车级电机

永磁同步电驱动，功率更大，动力更强

Automotive-grade motor

Permanent magnet synchronous electric drive delivers greater power and performance



汽车级防护

核心电气部件IP67，整车防护IPX4

Automotive-grade protection

IP67 for core electric components and IPX4 for the entire forklift



汽车级线缆

线束整洁，更可靠，更易维修

Automotive-grade cable

Neat harness, more reliable and easier maintenance



汽车级极致水冷

不惧高温工况

Automotive-grade water cooling

No fear of high temperature conditions

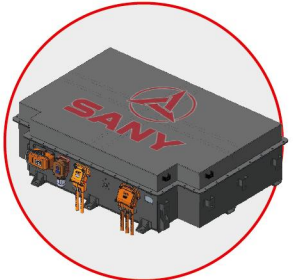

汽车级集成式锂电池 Automotive-grade integrated lithium battery

高安全性

汽车级动力电芯(磷酸铁锂)及电器元器件，电池管理系统能够实时故障检测上报仪表和云端智能平台，进行安全护航。

High safety

Automotive-grade power cells (lithium iron phosphate) and electrical components, the battery management system can detect and report faults in real time to the instrument and cloud intelligent platform for safe protection.

充电快

采用国标充电,兼容汽车充电桩，随用随充，快充模式适合多班次作业。

Fast charging

Adopt national standard charging, compatible with vehicle charging piles for convenient charging. The fast charging mode is suitable for multi-shift operations.

长寿命

五年或1万小时超长质保，放心使用。

Long service life

Enjoy an ultra-long warranty period of five years or 10,000 service hours for worry-free use.

环境适应性强

IP67 防护等级，可雨雪天作业；标配电池加热功能，保证低温环境正常工作。

Strong environmental adaptability

IP67 protection level, allowing operation in rainy and snowy days; Standard battery heating function, ensuring normal operation in low temperature environment.

经济性

锂电池无需人工维护；车辆整体使用运营成本低。

Economy

Lithium batteries, no manual maintenance required; the overall operating cost is low.

高效率

电池液冷系统,热损耗小，电能转化率高，可实现大倍率放电，动力强劲。

High efficiency

Battery liquid cooling system with low heat loss and high power conversion rate, achieving high-rate discharge and strong power.



行驶速度
Travel speed



满载爬坡度
Full load gradeability



满载加速
Full load acceleration



满载起升
Full load lifting Speed



电压平台
Voltage platform



标准电量
Standard battery power

紧凑型驱动桥

Compact drive axle

高转速 低噪音

High Speed with Low Noise

大速比

传动速比最大可达50

Large Gear Ratio

The maximum Gear Ratio can reach to 50

动力强

整车满载持续爬坡 $\geq 16\%$

Robust Power

Continuous climbing when fully loaded $\geq 16\%$

大承载

· 一体式铸造桥

· 主销结构采用大圆锥滚子轴承

High load capacity

· Integrated cast axle

· Tapered roller bearing for the king pin structure

可靠性高

设计寿命超20000h

High reliability

Design life of over 20000h

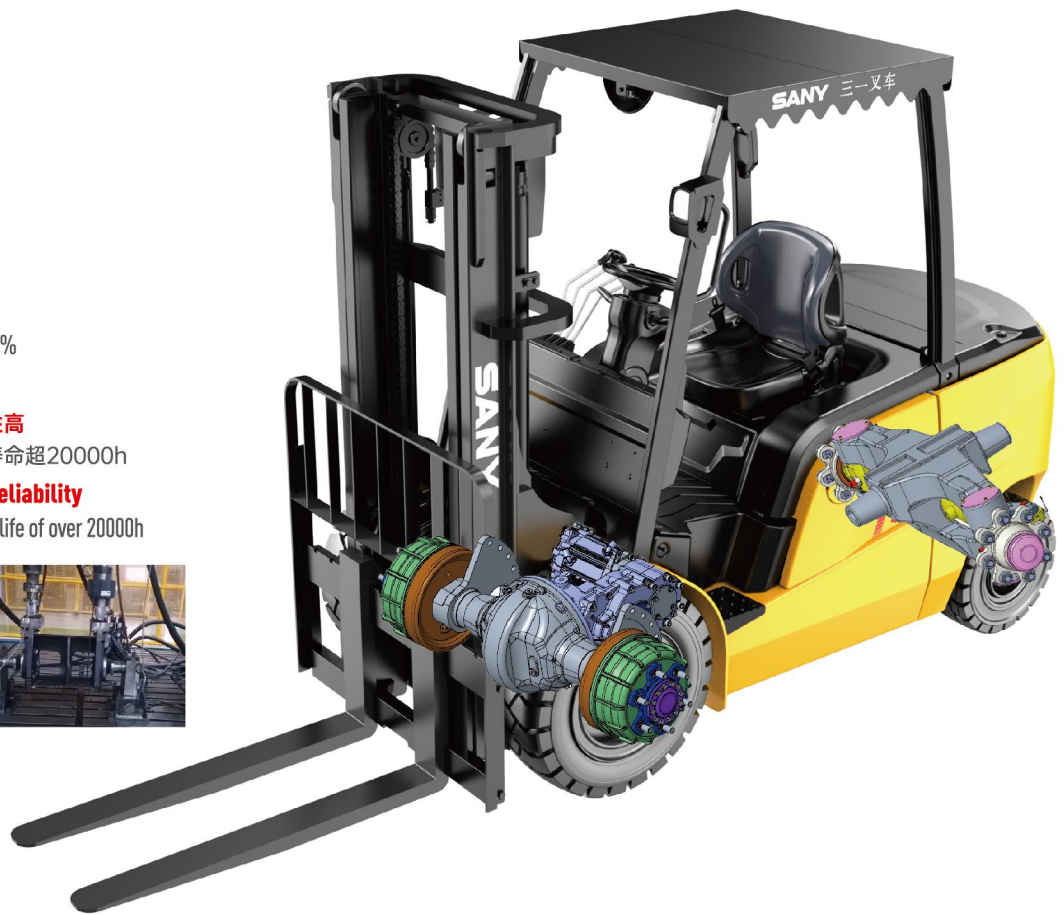

节能降本

Energy Saving and Cost Reduction

10-20%

综合节能
Comprehensive energy saving

30%

比传统电叉
可节省成本
Save costs compared to
traditional electric forklifts

2台三一电动叉车
2 SANY electric forklifts



3台燃油叉车经济效益
3 diesel forklifts in terms of economic benefits



安全可靠

High Safety and Reliability

主动安全系统 (选配):

可侦测人移动, 提前预判危险报警

Active safety system (optional):

Detect human movement and anticipate hazards with alerts



高精度人脸识别系统(选配):

确保驾驶员持证上岗

驾驶员动态感知系统(选配):

避免疲劳驾驶

High-precision facial recognition system (optional):

Ensure drivers are licensed

Driver dynamic sensing system (optional):

Avoid drowsy driving



超长质保, 使用无忧:

三电五年或一万小时质保

Ultra-long warranty, worry-free use:

Warranty period of five years or 10,000 service hours for EIC



智能服务

Intelligent Service

云端智能监控护航, 可进行车队管理, 远程故障诊断等。

Intelligent cloud monitoring allows for fleet management, remote fault diagnosis, etc.



电池管理系统
Battery management unit



云端智能监控
Cloud intelligent monitoring



车队智能管理
Motorcade intelligence management



远程故障诊断
Remote fault diagnosis



设备指标多样
Various equipment indicators



标配远程升级和锁车
Standard remote upgrade and locking



维修便利 Convenient Maintenance

一分钟可达任意维修角落，合理的部件布置，外罩拆除后所有部件均触手可及，维护更方便。

It takes only one minute to reach any part to be maintained. Reasonable component layout ensures all components are within easy reach after the shell is removed, making maintenance more convenient.



驾驶舒适 Comfort Driving

加速强劲、停车平顺、坡道辅助作业更轻松、精准、高效。

Powerful acceleration, smooth parking, and hill assist make operations easier, more precise, and more efficient.



行业领先的超大视野门架
Industry-leading wide-visibility mast



减震座椅，无惧颠簸，消除疲劳
座椅标配OPS开关，离位感应
Shock-absorbing seats to eliminate fatigue, equipped with OPS switch and seat occupancy sensor



标配智能仪表7寸大屏，
触摸操控，方便快捷
Standard intelligent instrument with 7-inch large screen, for intuitive and easy operation

售后服务 After-Sales Service

集团500多个服务网点，遍布全国县级市；100+“特种兵”服务人员；7X24小时热线服务；365天应急案件响应服务。

SANY has over 500 service stations nationwide, reaching county-level cities; 100+ "specialized" service personnel; 24/7 hotline service; 365-day emergency response service.

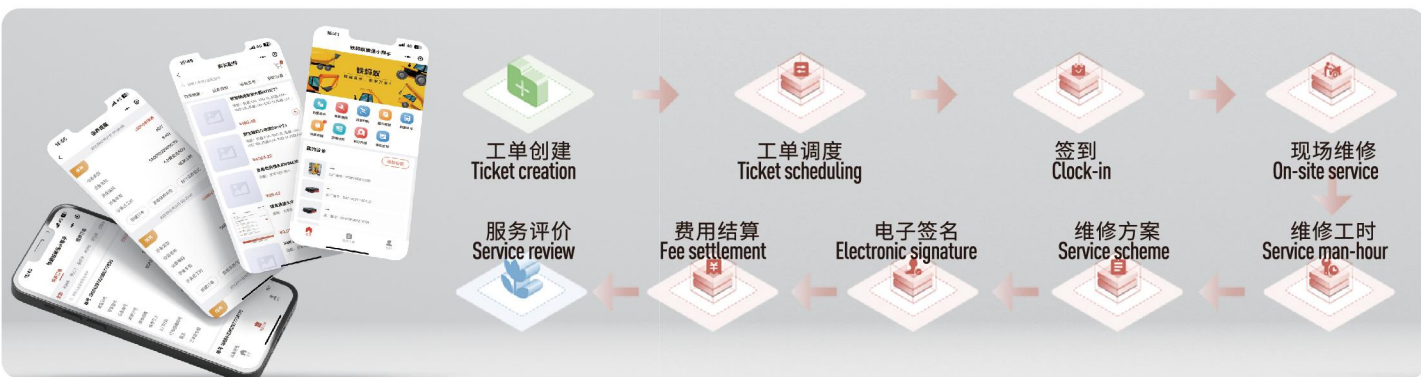

1
刻钟回复客户
Response to customers within 15 minutes



2
小时到达主要
服务区域
Arrive at the main service area within 2 hours



1
天内提供常用
维修配件
Provide common maintenance parts within 1 day



2
天内解决客户
投诉
Resolve customer complaints within 2 days



7
天内解决客户
遗留问题
Resolve customer outstanding issues within 7 days

参数 Parameters

分类 Category	单位 Unit	参数 Parameters		
概述 Overview	产品型号 Product Model	/	SCP30F1	SCP35F1
	额定载重量 Rated load capacity	Q(kg)	3000	3500
	载荷中心距 Load center distance	c(mm)	500	500
	前悬距 Front overhang	x(mm)	485	490
	轴距 Wheel base	y(mm)	1750	1750
重量 Weight	自重 Dead weight	kg	4670	5100
	轴载前后(满载) Axle load front/rear (full load)	kg	6700/970	7690/910
	轴载前后(空载) Axle load front/rear (no load)	kg	2150/2520	2200/2900
尺寸 Size	门架倾斜角(前/后) Mast tilting angle (front/rear)	$\alpha/\beta(^{\circ})$	6/12	6/12
	门架缩回时高度 Height when mast is retracted	h1(mm)	2130	2130
	自由提升高度 Free lift height	h2(mm)	130	130
	起升高度 Lifting height	h3(mm)	3000	3000
	门架起升时最大高度 Maximum height of raised mast	h4(mm)	4190	4190
	护顶架高度 Overhead guard height	h6(mm)	2190	2190
	总长(至货叉前端面) Overall length (to the front end face of forks)	L2(mm)	2680	2680
	总宽 Overall width	b1(mm)	1250	1250
	货叉尺寸(厚度/宽度/长度) Fork dimensions (thickness/width/length)	$s \times e \times l$ (mm)	45*122*1070	50*122*1070
	货叉间距 Fork spacing	mm	247-1100	247-1100
	最小离地间隙(满载) Minimum ground clearance (full load)	m1(mm)	130	130
	轴距中心处最小离地间隙 Min. ground clearance at wheel base	m2(mm)	150	150
	堆垛通道(1m x 1.2m) Stacking aisle (1 m x 1.2 m)	Ast(mm)	4050	4050
	堆垛通道(0.8m x 1.2m) Stacking aisle (0.8 m x 1.2 m)	Ast(mm)	4250	4250
	最小转弯半径 Minimum steering radius	Wa(mm)	2350	2350
轮胎 Tire	轮胎形式 Tire type	/	充气胎 Pneumatic tire	充气胎 Pneumatic tire
	前轮规格 Front tire specifications	/	28x9-15	28x9-15
	后轮规格 Rear tire specifications	/	21x8-9	21x8-9
	前轮距 Front wheel track	b10(mm)	1020	1020
	后轮距 Rear wheel track	b11(mm)	1000	1000
性能 Performance	最大行驶速度(满载/空载) Maximum travel speed (full load/no load)	km/h	16/16	16/16
	最大起升速度(满载/空载) Maximum lifting speed (full load/no load)	mm/s	350/400	350/400
	下降速度(满载/空载) Lowering speed (full load/no load)	mm/s	420/510	420/510
	牵引力(满载/空载) Traction force (full load/no load)	N	17300/15800	17300/15800
	爬坡度(满载/空载) Gradeability (full load/no load)	%	17/20	16/20
	行车制动 Service brake	/	液压式 Hydraulic	液压式 Hydraulic
驻车制动 Parking brake	/	机械式 Mechanical	机械式 Mechanical	
电机 电池 Moto battery	行走电机(S2-60min) Travel motor (S2-60min)	kW	17	17
	起升电机(S3-15%) Lifting motor (S3-15%)	kW	25	25
	电池电压/电量 Battery voltage / capacity	V/kWh	96/22.1	96/22.1
	电池自重 Battery weight	kg	210	210
控制器 Controller	行走电机控制型式 Travel motor control type	-	MOS管/交流 MOS transistor/AC	MOS管/交流 MOS transistor/AC
	属具提供压力 Pressure provided to MAST AUXILIARY	MPa	19.5	19.5

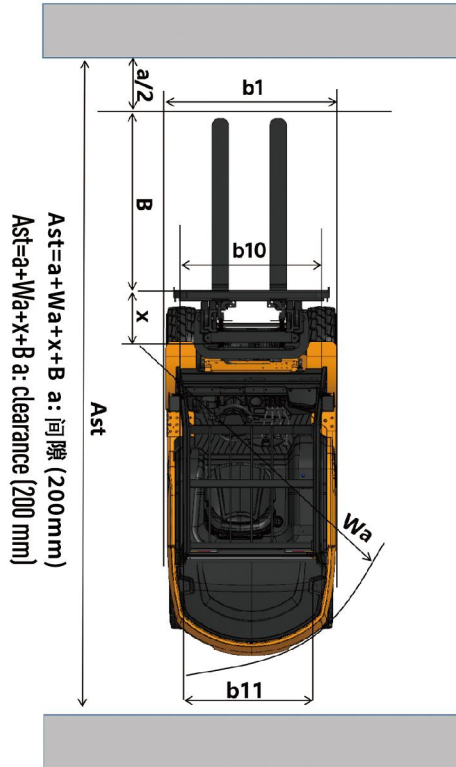
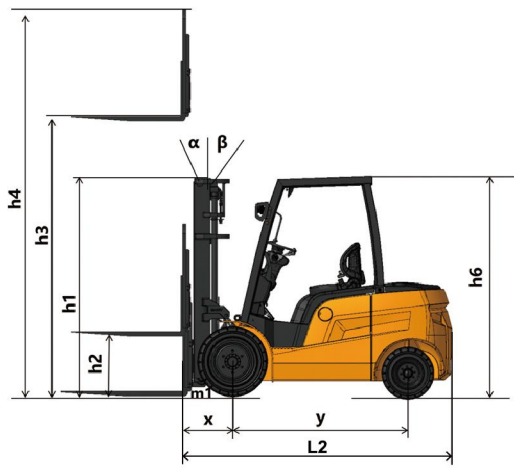

属具选配 MAST AUXILIARY OPTIONS

外挂式侧移器 External side shifter



安装等级: 2A, 3A
适用对象: 用于货叉需要侧移的工况
Mounting level: 2A, 3A
Application: Working conditions requiring fork side shifting

侧移调距器 Side shift distance adjuster



安装等级: 2A, 3A
适用对象: 用于货叉需要侧移和调距的工况
Mounting level: 2A, 3A
Application: Working conditions requiring fork side shifting and distance adjustment

旋转器 Rotator



安装等级: 2A, 3A
适用对象: 用于货物需要翻转和倾倒的工况
Mounting level: 2A, 3A
Application: Working conditions requiring goods flipping and dumping

单双托盘叉 Single/double pallet fork



安装等级: 2A, 3A
适用对象: 用于双托盘的搬运, 多用于啤酒厂
Mounting level: 2A, 3A
Application: Used for handling double pallets, mostly in breweries

纸卷夹 Paper roll clamp



安装等级: 2A, 3A
适用对象: 用于纸业对纸卷的搬运
Mounting level: 2A, 3A
Application: Used in paper industry for handling paper rolls

纸箱夹 Carton clamp



安装等级: 2A, 3A
适用对象: 用于纸业对纸箱的搬运
Mounting level: 2A, 3A
Application: Used in paper industry for handling cartons

推拉、推出器 Push-puller/pusher



安装等级: 2A, 3A
适用对象: 用于袋装货物、箱装食品等的搬运
Mounting level: 2A, 3A
Application: Used for handling bagged goods and boxed food

软包夹 Soft pack clamp



安装等级: 2A, 3A
适用对象: 用于废料回收物、废纸、软包类、纺织品等的搬运
Mounting level: 2A, 3A
Application: Used for handling waste recycling materials, waste paper, soft packs, and textiles



- 标配
- Standard configuration
- 选配
- Optional
- 无此配置
- Not configured

SCP			SCP30F1	SCP35F1
轮胎 Tire	充气胎	Pneumatic tire	●	●
	实心胎	Solid tires	○	○
	无痕胎	Non-marking tire	○	○
座椅 Seat	标准座椅	Standard seat	●	●
	悬浮座椅	Suspension seat	○	○
	进口悬浮座椅	Imported suspension seat	○	○
控制阀 Control Valve	OPS机械阀2联	OPS mechanical valve (2-way)	●	●
	OPS机械阀3联	OPS mechanical valve (3-way)	○	○
	OPS机械阀4联	OPS mechanical valve (4-way)	○	○
	十字遥控电磁阀2联	Cross-joystick solenoid valve (2-way)	○	○
	十字遥控电磁阀3联	Cross-joystick solenoid valve (3-way)	○	○
	十字遥控电磁阀4联	Cross-joystick solenoid valve (4-way)	○	○
	指尖操纵电磁阀2联	Fingertip-operated solenoid valve (2-way)	○	○
	指尖操纵电磁阀3联	Fingertip-operated solenoid valve (3-way)	○	○
	指尖操纵电磁阀4联	Fingertip-operated solenoid valve (4-way)	○	○
智能终端 Intelligent terminal	远程诊断功能	Remote diagnosis function	●	●
智能限速 Intelligent speed limit	智能转弯减速	Intelligent steering deceleration	○	○
门架 Mast	标准2级3m	Standard 2-stage 3 m	●	●
	标准2级3.5m	Standard 2-stage 3.5 m	○	○
	标准2级4m	Standard 2-stage 4 m	○	○
	标准2级4.5m	Standard 2-stage 4.5 m	○	○
	标准2级5m	Standard 2-stage 5 m	○	○
	2级全自由3m	2-stage free-lift 3 m	○	○
	3级全自由4.5m	3-stage free-lift 4.5 m	○	○
	3级全自由5m	3-stage free-lift 5 m	○	○
	3级全自由5.5m	3-stage free-lift 5.5 m	○	○
	3级全自由6m	3-stage free-lift 6 m	○	○
管路 Pipeline	单附加属具管路(标准门架)	Single additional MAST AUXILIARY pipeline (standard mast)	○	○
	双附加属具管路(标准门架)	Double additional MAST AUXILIARY pipeline (standard mast)	○	○
	单附加属具管路(2级自由门架)	Single additional MAST AUXILIARY pipeline (2-stage free-lift mast)	○	○
	双附加属具管路(2级自由门架)	Double additional MAST AUXILIARY pipeline (2-stage free-lift mast)	○	○
	单附加属具管路(3级自由门架)	Single additional MAST AUXILIARY pipeline (3-stage free-lift mast)	○	○
	双附加属具管路(3级自由门架)	Double additional MAST AUXILIARY pipeline (3-stage free-lift mast)	○	○



- 标配
- Standard configuration
- 选配
- Optional
- 无此配置
- Not configured

SCP			SCP30F1	SCP35F1
货叉 Fork	1070mm	1070mm	●	●
	不要货叉	No fork	○	○
	1220mm	1220mm	○	○
	1370mm	1370mm	○	○
	1520mm	1520mm	○	○
	1670mm	1670mm	○	○
	1820mm	1820mm	○	○
	2000mm	2000mm	○	○
灯 Lamps	标准照明(前后组合灯)	Standard lighting (front and rear combination lamp)	●	●
	频闪警示灯(黄色)	Strobe warning light (yellow)	○	○
	频闪警示灯(蓝色)	Strobe warning light (blue)	○	○
	后照明灯	Rear working light	○	○
	蓝光斑点灯	Blue spot light	○	○
	边界警示灯带(蓝色)	Boundary warning light strip (blue)	○	○
	边界警示灯带(红色)	Boundary warning light strip (red)	○	○
	标准护顶架	Standard overhead guard	●	●
驾驶舱 Cab	前挡风+顶部PC,雨刮器,喷水壶+风扇	Front windshield + top PC, wiper, sprinkler can + fan	○	○
	全舱驾驶室+风扇	Full can + fan	○	○
	全舱驾驶室+风扇+电暖风	Full can + fan + electric heater	○	○
电池 Battery	15度	15 kWh	-	-
	22.1度	22.1 kWh	●	●
	31度	31 kWh	○	○
	40度	40 kWh	○	○
	50度	50 kWh	-	-
	7kw(22V民用用电,输出电流20A)	7 kW (22 V residential power, output current 20 A)	○	○
	50A(380V工业用电)	50A (380 V industrial power)	○	○
	100A(380V工业用电)	100A (380 V industrial power)	●	●
充电器 Charger	200A(380V工业用电)	200A (380 V industrial power)	○	○
	20kw(380V工业用电)	20 kW (380 V industrial electricity)	-	-
	30kw(380V工业用电)	30 kW (380 V industrial power)	-	-
	60kw单枪(380V工业用电)	60 kW single charger (380 V industrial power)	-	-
	60kw双枪(380V工业用电)	60 kW double charger (380 V industrial power)	-	-
	80kw单枪(380V工业用电)	80 kW single charger (380 V industrial power)	-	-
属具 Attachment	外挂侧移	External side shifter	○	○

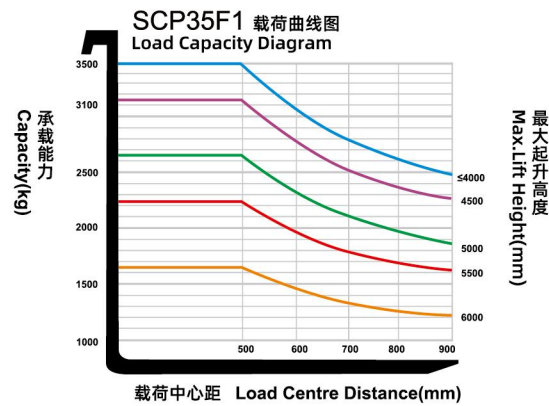
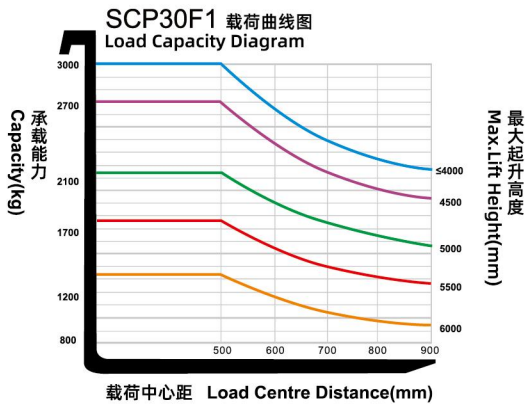

门架参数 Mast parameters

门架类型 Mast type	门架型号 Mast model	最大起升高度 Max. Lift Height	SCP30F1/35F1						
			承载能力(载荷中心500mm) Capacity (load center 500mm)		门架落地全高 Full height of mast	门架作业最大高度 Maximum operating height of mast		自由起升高度 Free lift height	门架倾角 Mast sloping angle
			3.0t	3.5t		无挡货架/带挡货架 No load backrest/with load backrest			
			mm	kg	kg	mm	mm	mm	°
二级宽视野门架 Stage II wide-view mast	S30	3000	3000	3500	2140	3730/4200		125	6/12
	S35	3500	3000	3500	2390	4230/4700		125	6/12
	S40	4000	3000	3500	2740	4730/5200		125	6/10
	S45	4500	2700	3150	2990	5230/5700		125	6/6
	S50	5000	2350	2750	3240	5730/6200		125	6/6
二级全自由门架 Stage II free-lift mast	D30	3000	3000	3500	2140	3730/4200		1400/930	6/12
三级全自由门架 Stage III free-lift mast	T45	4500	2500	2900	2180	5265/5700		1410/970	6/6
	T50	5000	2100	2500	2450	5765/6200		1680/1240	6/6
	T55	5500	1700	2000	2610	6265/6700		1840/1400	3/6
	T60	6000	1200	1500	2830	6765/7200		2060/1620	3/6



三一机器人科技有限公司
SSANY Robotics Technology Co., Ltd.

地址：湖南省长沙市长沙县三一工业园东厂区21号厂房
Address: Building 21, East Factory Area, SANY Industrial Park, Changsha County,
Changsha City, Hunan Province, China

邮编：410100 电话：400-810-0318
Zip code: 410100 Tel: +86 400-810-0318

温馨提示：
由于技术不断更新，技术参数及配置如有更改，恕不另行通知。图片上的机器可能包括附加设备，本画册仅供参考，以实物为准。

Note:
Due to ongoing technological updates, technical parameters and configuration are subject to change without notice. The machine shown in the image may include additional equipment; this catalog is for reference only, and actual products shall prevail.

© 中国印刷 2024 年 11 月版
© Printed in China, November 2024 Edition



官方网站
Official Website



官方订阅号
Official Subscription
Account



官方视频号
Official Video
Account



官方抖音号
Official TikTok
Account