

PRODUCT HIGHLIGHTS

ELECTRIC ROAD ROLLER | STR50E

SANY

Quality Changes the World

ELECTRIC LONG ENDURANCE

ALL-ELECTRIC DRIVE SCHEME,
HV FAST CHARGING

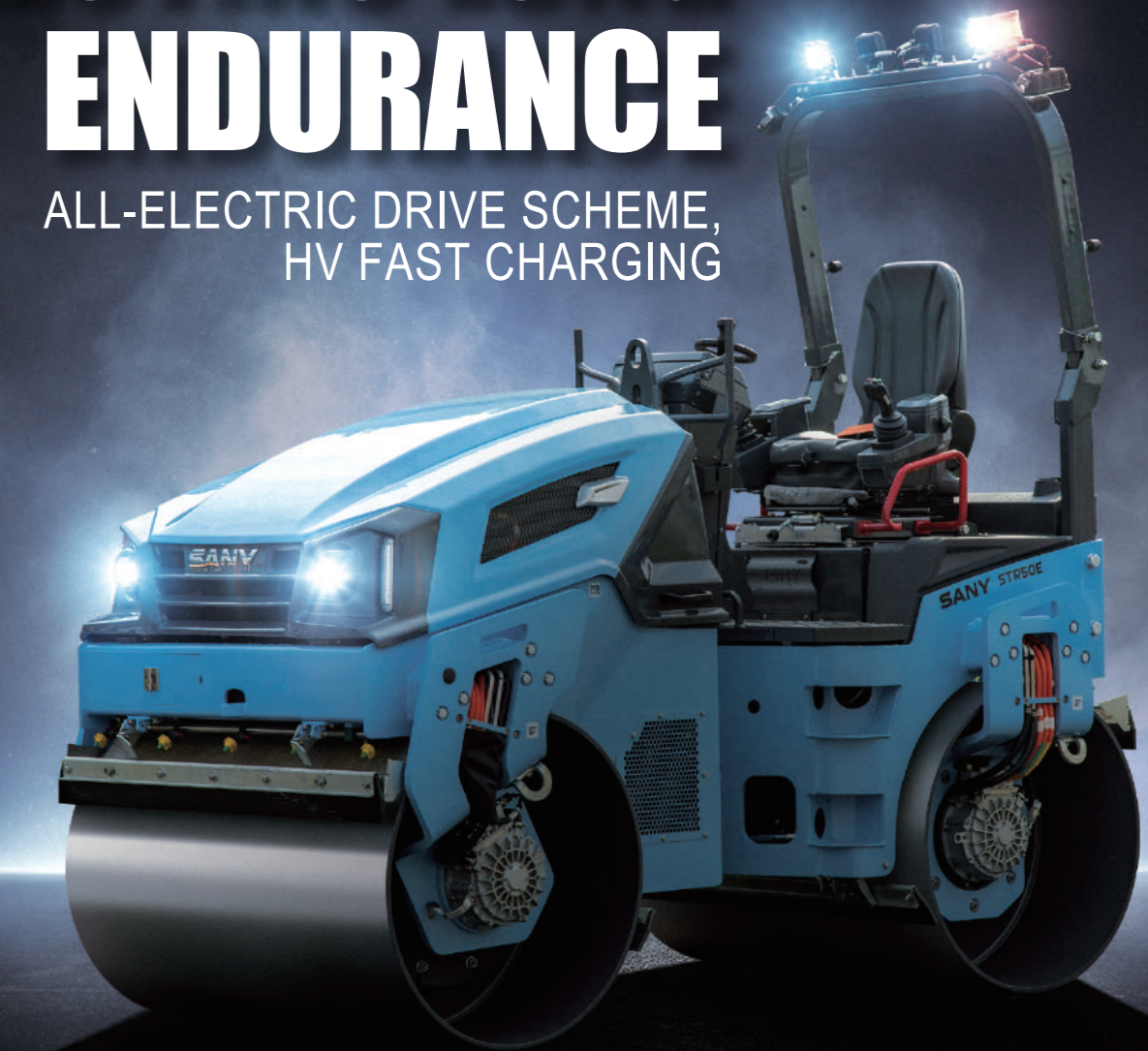

EFFICIENT AND RELIABLE

AC synchronous motor drive system for travelling and vibration, with energy consumption reduced by 20% and regenerative braking system during braking.
The world's leading high-quality supplier of battery, motor and electronic control, safe and reliable.

CONVENIENCE

Shared car charging pile, fast charge for only 60 min at a time.
No engine maintenance is required, and a full charge using a household slow charger only costs RMB 30

ECO-FRIENDLY AND ECONOMIC

Electric drive, zero pollution and emission, noise reduced by 20% during static rolling operation.
More than 60% of the comprehensive operation cost (fuel and maintenance costs) can be saved.
Meet the operation requirements of a typical working day.

ROAD MACHINERY

SANY

Quality Changes the World

SANY EUROPE GmbH
Sany Allee 1
D-50181 Bedburg
fon +49 2272 90531 100
fax +49 2272 90531 109
info@sanyeurope.com
www.sanyeurope.com

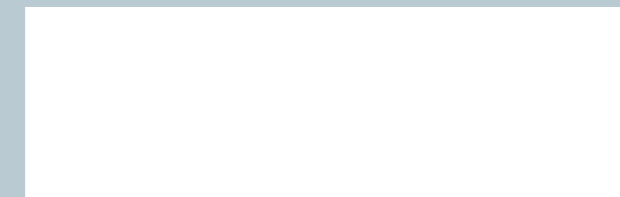

Not all products are available in all markets. As part of our continuous improvement process, we reserve the right to modify specifications and designs without giving prior notice. The figures may contain additional options.



ELECTRIC ROAD ROLLER
STR50E

Battery capacity
60 kWh
Centrifugal force of front drum
46/62 kN
Working width
1 380 mm
Operating weight
4 750 kg

LONG ENDURANCE AND LOW COST

60KWh Battery, 348V.

Electric Drive System: Vibration and travel functions utilize direct-drive electric motor technology.

Large-capacity battery + high-efficiency electric system, meeting the construction requirements of at least one shift.

Low maintenance cost of the battery, motor and electronic control systems. And only routine maintenance is required.

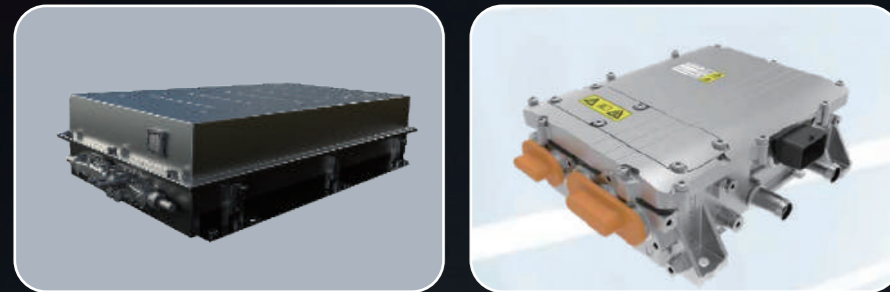

EFFICIENT AND ACCURATE

The maximum driving efficiency of the motor is 95%, and 90 in the working condition range. The system efficiency is improved and the heat loss is significantly reduced;

Regenerative braking system can be carried out like automobiles, and the energy feedback rate is up to 60%;

The electric drive and battery system can be heated as required, and the flow rate and fanspeed are adjusted in real time according to the temperature to reduce energy consumption.

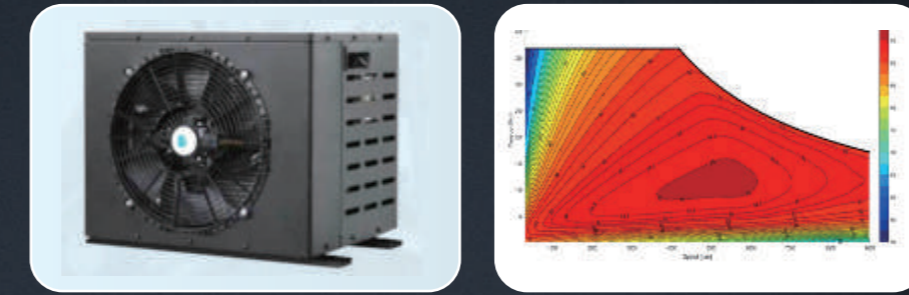

PRODUCT OPTIONAL CONFIGURATION

Item	Description of additional/optional configuration	Comment
Canopy	Configuration of control platform canopy	Optional
Intelligent compaction system	Used for online detection of compactness on construction site	Optional

*: The above configurations need to be priced separately.

ECONOMIC VALUE ANALYSIS

SANY STR50E electric tandem drum roller can create an additional value of €4 600 for customers every 1 000 hours.

1. Low energy consumption and long endurance - annual savings: €4 200 (vs. diesel models)

TCO calculation based on EU electricity price €0.32/kWh

2. Initiate more works

There is no noise in the static pressure process, and there is no complaint at night or during densely populated operation.

There is no emission in electric operation, and there are no restrictions on municipal work.

Note: Calculated as 1 000h yearly.

3. Low maintenance cost - annual savings: €420

The battery, motor and electronic control system only needs simple maintenance, annual savings: €420 (vs. diesel models).

PRODUCT PARAMETERS

Overall dimensions

The following are standard configuration measurements; actual values may vary depending on optional components.

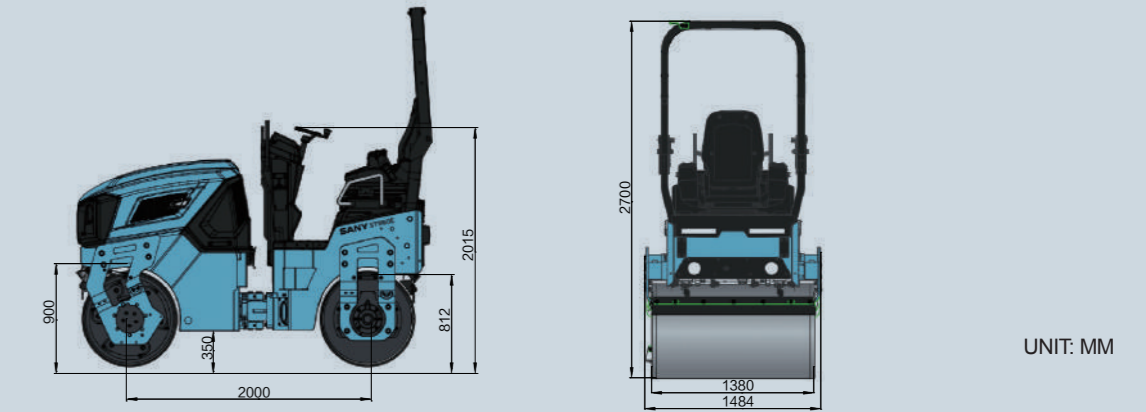

Item	STR50E
Battery capacity (kWh)	60
Type of power battery	Lithium iron phosphate
Power of travel motor (kW)	20
Vibration motor power (kW)	7.3
Operating mass (kg)	4 750
Static linear load (N/cm)	160
Frequency (Hz)	50/58
Amplitude (mm)	0.5
Centrifugal force (kN)	46/62
Steel drum diameter/width (mm)	900/1 380
Max. gradeability without/with vibr. (%)	30/40
Direct Current Fast Charging (DCFC)	Available
AC Slow Charging	Available

*: ±10% voltage tolerance

CONVENIENT CHARGING

Universal vehicle charging pile, with fast charging and slow charging systems.



Rapid charging achieves 80% SOC in 1h (CCS2 DC), while a 30-minute charge delivers 3h runtime.

Flexible charging solutions support on-site deployment wherever grid access is available.



HIGHLY RELIABLE BATTERY, MOTOR AND ELECTRONIC CONTROL COMPONENTS

The battery scheme that meets the work mechanical vibration requirements is adopted.



Liquid cooling thermal management system + battery self-heating, suitable for both hot and cold environments.

The bearing capacity of the motor and high anti-seismic design of the structure can withstand an impact of more than 10g.

IP68 certified (IEC 60529) for high voltage system.

SANY INTELLIGENT CONTROL TECHNOLOGY

Independent control of front and rear wheels, upgraded flexible start/stop, better smoothness, ASR.

Vibration of front and rear drums is controlled independently, with continuous modulation of vibration frequency.

The electric drive and battery system dissipate heat as required, and the flow rate and fan speed are adjusted in real time according to temperature.

Optional intelligent compaction monitoring system.

